

4

3

2

1

D

D

C

C

B

B

A

A

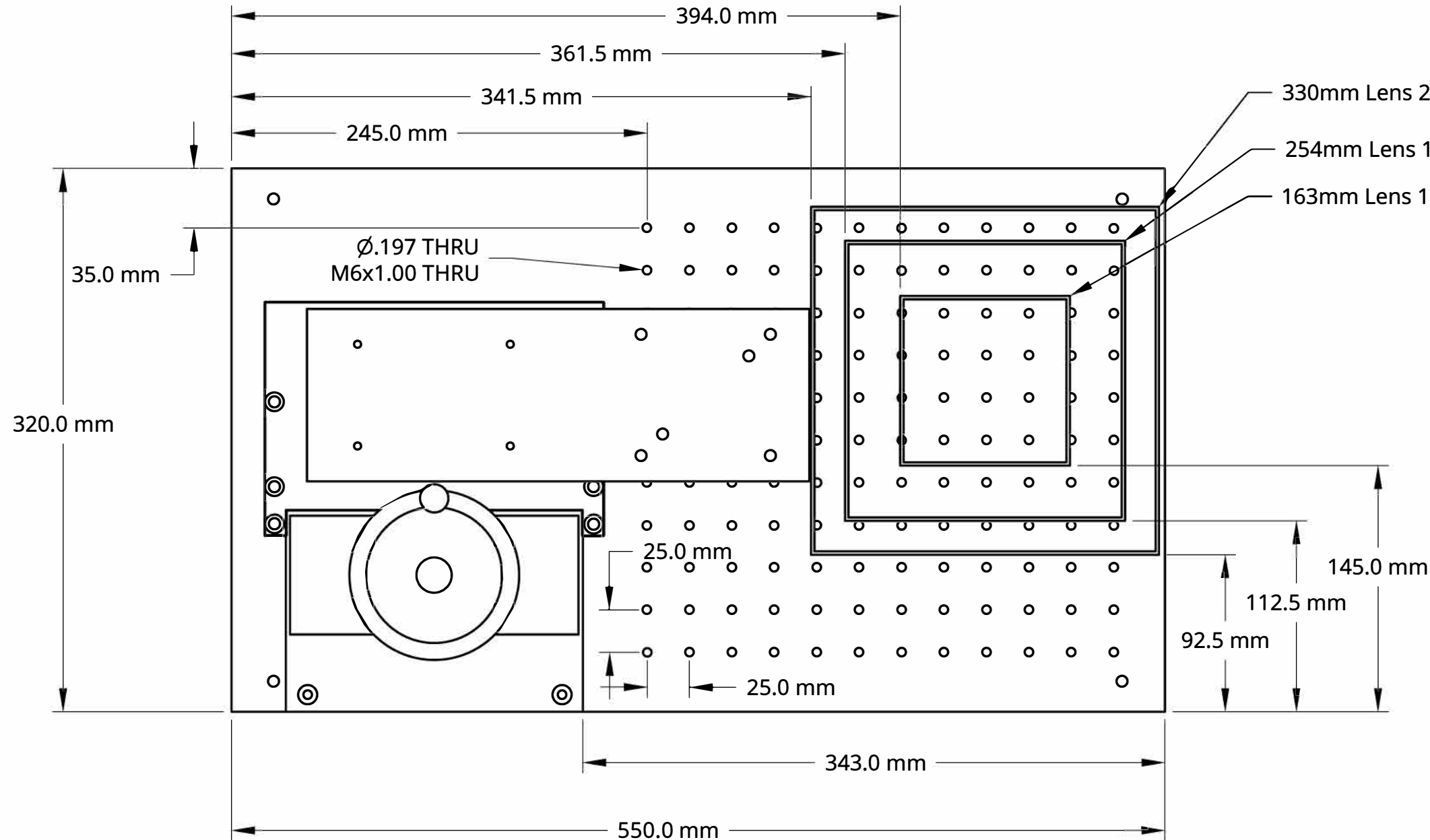

Tool post	Lens	Max Part Height
500mm	163	340mm
500mm	254	230mm
500mm	330	140mm
800mm	163	640mm
800mm	254	530mm
800mm	330	440mm

SCALE 1:3

UNLESS OTHERWISE SPECIFIED,
DIMENSIONS ARE IN INCHES

.X = ±.100
.XX = ±.010
.XXX = ±.005
.XXXX = ±.0005

ANGULAR = ± 1/4°
FRACTIONAL = ± 1/32

SURFACE FINISH ✓

DO NOT SCALE DRAWING

BREAK ALL SHARP EDGES AND REMOVE BURRS

THIRD ANGLE PROJECTION



	NAME	DATE
DRAWN	Trent Strawser	11/02/2018
CHECKED		
APPROVED		
MATERIAL		
FINISH		



TITLE		
TOOL POST ASSY LASER GEAR		
SIZE	DWG NO.	REV.
B	11218	---
SCALE	WEIGHT	SHEET
1:6		1 of 1

4

3

2

1